



**Bailey Foster Appeal**



## Thank You!

**We would like to thank you for the support we have received, with our Bailey Foster appeal.**

The appeal has been well supported by our customers and suppliers, and is on course to reach target very shortly.

## Customer Care or Cash

### - which is king?

We would like to reassure all of our customers, that PROCare do not, nor do we intend to become competition to your business.

We are a true distributor who are committed to bringing you the best products, prices and services available.

It comes as no surprise to find out that a number of Regional suppliers are now offering supply and fit packages within the Local Authority / Social Housing market.

These companies have offered savings to take your orders, now they want to take your livelihood.

We would like to take this opportunity to thank our customers for their valued custom and loyalty throughout these current economic times.

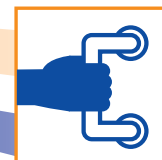
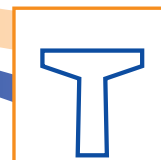
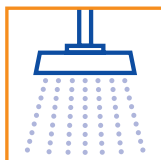

# New Products & Website



the professionals choice  
wet floor and bathroom specialists

Home >>

About us >>

Products >>

Services >>

Showroom >>

Contact us >>

## Expert Help

Our sales team can offer expert help and guidance to ensure you receive the product that meets your requirements & our specialist knowledge and commitment to this industry enables us to deliver the best value to our customers



### Showroom

Our fully functioning showroom has been designed to hold seminars, training days, customer assessments & product releases

[Read More](#)



### Products

Our technical advisors can offer help & guidance to ensure you receive the product that meets your requirements

[Read More](#)



### Guarantees

Guarantee and Maintenance information for our products all listed in one easy to follow guide

[Read More](#)



We have now launched our new website, where you can view product specifications, videos and download brochures. We will keep you updated with our future news, developments and product releases.

One such product is our unique wet floor former gully. The gully comes complete with a gravity and pump base plate which ensures the correct choice.

It has a user friendly cleaning cover (No Screws), a unique filter basket which can be used for pumped or gravity installations and is compatible with our PROPump Gold, fault finder.

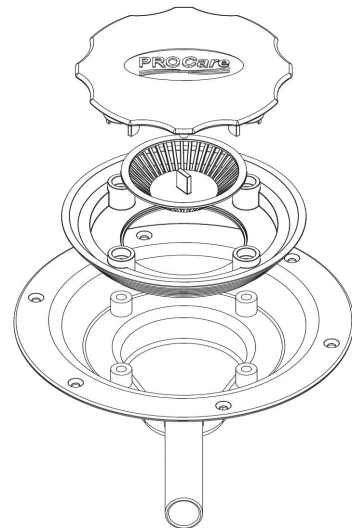

delivering best  
**value**



01942 206 004

[www.procare-ltd.co.uk](http://www.procare-ltd.co.uk)

Enfield Industrial Estate : Enfield Street : Pemberton : Wigan : WN5 8DB